

K-30603

studio *magazin*

39. JAHRGANG · NR. 426

**English
Translation**



TEST: KII THREE PRO

STORY: MIKROFONE UND WANDLER

TEST: CROOKWOOD M4



Actually, the Kii Three is not purely a studio monitor. There is also a hi-fi version, which is currently all the rage in the audiophile community, the only distinguishing feature between the two being the cabinet finish. The fresh, life-affirming dark grey that adorns the pro version of the Kii Three is the same that can be found on countless 19" boxes due to the strange but magical attraction this colour seems to exert on the production world – for whatever reason. Maybe the point is to reduce the visual impact of your loudspeakers and generally all your control room tools.

But first things first. How simple would the world be if there was just one single reference speaker, to be used in production as well as for home listening. There's so much to be said for it – if only the laws of physics, thousands of years old and still unwilling to change, wouldn't oppose: The room in which a loudspeaker is playing will always have a profound influence on the acoustic result.

Minimizing this influence is a quintessential element in the Kii Three design concept that should benefit both home listeners and studio engineers. Concepts of controlled directivity and beam steering are far from new, they can be found in line arrays for live PAs, in the cardioid bass of the K series by Musikelectronic Geithain, in Barefoot monitors and in various hi-fi designs. However, the advanced DSP implementation accomplished by Kii Audio looks like a new way that only very few designers have taken before.

FRITZ FEY, PHOTOS: FRIEDEMANN KOOTZ, GRAPHICS: KII AUDIO

VOYAGE OF DISCOVERY

KII THREE PRO STUDIO MONITOR

The conflicting priorities between production and pleasure listening keep giving rise to the same question: should a home loudspeaker enhance a mediocre recording to make it a special experience, or is it allowed to confront the listener with the recording the way it actually sounds.

Ideally of course, both sound engineer and music listener should hear the same. If both are hearing “correctly” then a common ground is established to allow communication on a level playing field. However, the vast differences in room acoustics between a purpose built control room and a domestic lounge will prevent this from happening. Which is why rendering the loudspeaker more impervious to room influence is an important step towards creating the ideal listening situation.

It happened to me more than once that honest loudspeakers spoiled the fun in recordings that I cherished musically. With a Kii Three in a domestic living room, this could happen to its proud owner as well. Notoriously, the studio landscape has seen dramatic changes over the past two decades. Today, almost anyone can afford a DAW based production system and, thanks to a great variety of presets, operate it, too. But the room acoustics surrounding many of these systems were neither designed nor built to professional standards. So again, a loudspeaker capable of minimizing room interference would be very helpful.

Room acoustics issues appear predominantly at low frequencies and when trying to achieve precise stereo imaging. While the latter can be optimized by comparatively simple measures, taming the low frequencies takes a much larger effort (see also our special edition *Room Acoustics and Studio Design*, June 2016). This is where the Kii Three comes in, creating a consistent cardio-oid sound field all the way down to just short of 50Hz, then gradually becoming omnidirectional below this point. With

the Speaker placed close to a wall and thus at an acoustically benign boundary distance, the resulting level increase below 50Hz can easily be treated in a compensation filter.

Background

Kii Audio GmbH was founded in August, 2014, originally aimed at the audiophile market. The Kii Audio team consists of five members, each with an impressive track record in our business: CEO Chris Reichardt worked for various well-known brands before starting his own distribution company Audio Import; CTO Bruno Putzeys pioneered Class D amplification technology and, to give just one further example, designed key elements of the highly praised LS1 by Grimm Audio; COO Bart van der Laan possesses comprehensive knowledge in embedded software development and DSP programming; production & QC manager Wim Weijers managed a company specialized in the modification and fine-tuning of audio components. Finally, product manager Tom Jansen worked as an acoustics and studio designer, single-handedly organized the Pro Audio Gear shows in Cologne and Hamburg, and has been successful as a product manager for Audio Import. We thus have five passionate professionals combining their individual strengths to cover the whole range from research and development to production, marketing and distribution.

Overview

The Kii Three was designed to provide extremely deep bass from a relatively small and surprisingly lightweight cabinet. An additional objective was to create dispersion characteristics equalling those of a flush mount monitor, notwithstanding the relatively narrow baffle. The smaller the loudspeaker front, the earlier (higher in



frequency) the speaker's dispersion will become omnidirectional – an unwelcome property in loudspeakers that studio planners go to great lengths to avoid. The relatively narrow cabinet consists of two shell halves which are injection molded from a specially formulated, low resonance polymer, basically substituting originally heavy components with a low density material of favourable vibrational properties. A first look reveals a very generous driver complement, with four woofers – one on each side panel plus two on the back – assisted by a bass-midrange driver and a tweeter with integral waveguide, both mounted to the front baffle. On the rear, we also find a small control panel which we will describe in more detail in just a minute, but which represents only the tip of a veritable iceberg of internal DSP and amplification complexity. The latter results primarily from the specific method of beam steering employed here, but is further complicated by I/O configuration, driver equalization, crossover frequency control and elaborate filtering resulting in an almost perfect impulse response. Accordingly, each Kii Three monitor houses a six channel DSP, six D/A converters and six power amp channels feeding each driver with its very own dedicated signal.



The power amps were designed by Bruno Putzeys as a refined version of his Ncore technology otherwise marketed under the Hypex brand. The Kii amps feature sophisticated voltage/current control circuitry to actively reduce distortion in each transducer. Six power amps at 250 watts each sum up to 1.500 watts of total power for each speaker. While this doesn't mean that the Kii Three can replace a PA system, our listening tests (described in more detail later) found cabinet size and maximum SPL throughout the entire audio spectrum to be mutually disproportionate to an almost absurd degree.

The control panel offers a single XLR input that accepts both digital and analog sources. Source selection is performed through a three-position switch (AES Left Channel, Analog, AES Right Channel). There's also two RJ45 sockets (In, Through) to connect one loudspeaker and daisy-chain the second when used in digital AES mode. The "Boundary" rotary selector lets you adjust the compensation EQ in 16 steps ranging from free field to near-wall and corner placement. The "Contour" selector lets you tune the speaker to your preferences, offering a linear position and a choice of 14 EQ presets with various Hi/Low shelf

combinations at 300Hz (Low) and 3/10kHz (Hi).

The presets are grouped around three different Low settings (B, F, C for boost, flat and cut), with five treble filter combinations for each: b (3kHz) for boost, a (10kHz) for air, f for flat, s (10kHz attenuation) for soft and c (3kHz attenuation) for cut. So the single rotary selector lets you dial in a large variety of settings. You can boost or attenuate low frequencies or leave them unchanged, and at the same time add boost or attenuation (or nothing at all) at 3kHz and 10kHz – in any combination imaginable. The Boundary selector described above works independently of this setting.

Beam Steering

Looking at the number and placement of bass drivers in the Kii Three, one might jump to the conclusion that its designer aimed to emphasize omnidirectional dispersion at low frequencies. But as a matter of fact quite the opposite is the case here.

For a basic understanding of beam steering, let's look at how to attain cardioid dispersion with just two drivers: You run the drivers in anti-phase and add a delay that is equivalent to the distance between the two.

If for example the speakers were 60 centimeters apart, a delay of 2 milliseconds would be required. On one side of this driver arrangement, the audio output should then in theory cancel out completely. This is comparable to how a cardioid microphone works. Each Kii Three employs two beam steering arrangements as illustrated in the picture sequence above. They consist of four low frequency drivers – two on the back of the cabinet and one on each side panel. The two woofers on the back form a cardioid system that works well from around 80Hz up to about 250Hz. Above 250Hz the wavelength becomes too short and renders the rear bass pair ineffective. In order to achieve the same effect at higher frequencies, the drivers have to be closer together. Which is why the second beam steering array consists of the frontal and both side mounted drivers. This results in a cardioid characteristic extending all the way up to 700Hz.

Further up in frequency, the intrinsic directivity of the front mounted drivers begins to take over. Thus, the actively controlled directivity at low frequencies combines with the "natural" directivity at mid/high frequencies to form a system that maintains fully cardioid dispersion down to 80Hz and abrupt-

ly turns omnidirectional as it goes lower (at around 50Hz). That way, the Kii Three performs like an in-wall system if placed in sufficient proximity to the rear wall. The low bass boundary gain in the range of omnidirectional radiation can be compensated by a built-in shelving filter (the said „Boundary“ selector).

With respect to side wall reflections the Kii Three shows a similar behaviour to that of a conventional loudspeaker, therefore similar geometrical and absorptive measures will have to be taken to provide a clean acoustic path to the listening position. The digital filter network in the Kii Three has to meet several objectives: the cancellation of acoustic byproducts from the two beam steering arrays, correction EQ for each individual driver, filters for beam steering and mid-treble crossover and finally the phase correction for an ideal impulse response – which in itself is pretty complex as it will be in-



fluenced by all the other filters. All this complex signal processing costs the user dearly – not financially, but by introducing a latency of 90 milliseconds which would disqualify the Kii Three for any kind of real time work in the control room. To avoid this, the monitor can be set to a low latency mode by pushing a button marked “P/R“ on the back panel, reducing the latency to only a handful of DSP samples plus the DAC latency for a total value in the one millisecond range. The low latency mode replaces the highly complex low frequency filters by simplified algorithms, leaving the sonic properties of the monitor basically unchanged. The only tradeoff is reduced precision at low frequencies, but at a very reasonable magnitude with only small impact on aural evaluation. If you really want to hear the smallest needle drop and your studio tasks are not time critical (such as mastering or mixing), you’ll gladly accept the 90ms latency.

Kii Control

Not currently available but expected to launch in the near future, a remote unit by the name of Kii Control will serve as volume control and offer additional digital inputs and basic monitor control functionality such as mute, dim and standby. The extra inputs will include optical and coaxial S/PDIF as well as USB, the latter being capable of high resolution audio with sample rates up to 384kHz at 24bits or DSD128. Volume control is performed in the DSP with no loss of signal resolution. Kii

Control will also feature infrared connectivity and an OLED display to access various presets and additional functionality through a menu-based user interface. The price for this system add-on is expected to be around 1300 Euros including tax.

Listening

In preparation of the listening tests I had once again asked my friend Klaus-Dieter Keusgen for support. The confined space of my own control room did not allow for convenient placement of the speakers. Therefore, it was in the spacious control room at Keusgen Tonstudio in Haldern by the beautiful Lower Rhine that we met with product manager Tom Jansen – a proven fan of the annual Haldern Pop Festival that takes place right outside the studio gates. Over the past years Keusgen Tonstudio has become an integral part of the festival schedule, with its large recording room serving as location for concerts with smaller audiences. Setup was quick and straightforward, leaving almost the entire day for our listening sessions and some short breaks spent leisurely chatting on 19“ erotica. The Keusgen Tonstudio control room is equipped with two flush mounted Genelec 1039A monitors with twin 15“ woofers and shows no shortage of bass by any account. All the more surprising was the phenomenal low frequency reproduction of the Kii Three. Loudspeakers this size sounding like in-wall battleships clearly wasn’t what I had anticipated. Along with sheer sca-

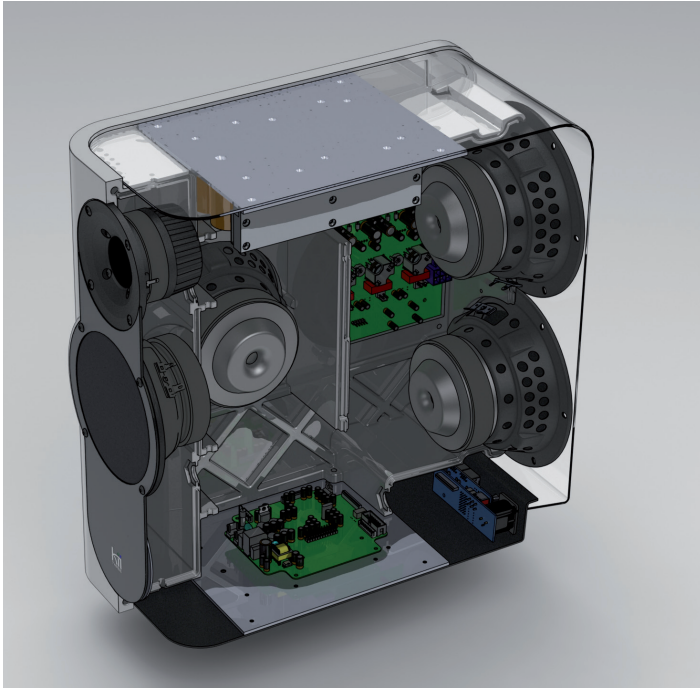

3D rendered interior view of the Kii Three Pro, right side shell and bass driver removed

le came outstanding low-end control with highly accurate transient and pitch definition – really outstanding. Although the speakers were placed right in front of the Genelecs, their sound was well detached from its physical source, tangible and three-dimensional like the sound of a pair of large flush mounted monitors. Behind the loudspeakers, there was actually almost complete silence in the fundamental frequency range.

What you see of this loudspeaker is in stark contrast to its sound in the lower registers: powerful, extending down to 20Hz with no audible limitation, the Kii Three system remained controlled, transparent and open even at very high sound pressure levels. No loudspeaker of this size that I am aware of can deliver bass of a comparable magnitude – or even come close in this respect. And you don't just hear a thick, cloudy thump, but a precisely arranged picture of all low-frequency sounds. This precision extends right through the midrange and treble. Clear, uncoloured mids, effortless, „accurate“ highs, extremely clean and fast transients, great spacial depth, a superbly focused stereo image with an equally well defined phantom center, and an open book of pinpoint localization.

These speakers seem to do it all: almost completely linear transmission in the frequency domain (which could actually be proven by measurement in the control room) and highly accurate temporal performance. This precision does come at a price, ruthlessly revealing the sub-par recordings and productions that keep frustrating the music lover in me: audible activity of compressors and limiters, bad vocal or

instrumental balance, lack of impact, resonances, overfiltered tracks, screechy highs or mids – the entire repertory of ugly mixing and recording errors presents itself most annoyingly. Yet this is perhaps the greatest compliment you can pay a loudspeaker. For the coherence of productions by more talented colleagues is depicted just as impressively, delivering true listening bliss once the golden master is on the “platter“. Actually, with this loudspeaker in a well equipped control room, you really shouldn't be making mistakes anymore. Unless you are completely clueless about your job, that is. The Kii Three Pro delivers an entirely coherent sound if everything is right, and immediately starts scolding you if anything isn't.

Conclusion

With the Kii Three Pro, the Kii Audio team enriches the world of loudspeakers with a tool of outstanding precision that is designed to significantly improve low frequency problems in the listening room – as long as they are within the “responsibility“ of the loudspeaker and its dispersion properties. Although its design requires free placement, the speaker removes this “problem area“ from the room just as effectively as a flush mounted speaker. Obviously, the beam steering method has no effect on the reverberation properties of a given room. Neither will it reduce ceiling and side wall reflections, where the Kii Three will behave just like many other good loudspeakers.

In any case, however, this loudspeaker impresses with its frequency response linearity, its outstanding time domain performance and an accurate depiction of minute detail that turns many a listening session into a voyage of discovery. If this performance will enthral audiophile enthusiasts? Fortunately, that is not for us to decide. However, real music lovers seem to increasingly want to hear a recording as it was intended by the sound engineer. In production, Kii Audio gives us a reliable tool that allows us to work over extended periods of time with extreme precision, yet completely fatigue free. Our brains may be able to compensate frequency anomalies with some effort, yet in the time domain this capability either fails completely or strains us to the point of premature exhaustion.

At 10.000 Euros per pair, these loudspeakers will be considered a bargain in the HiFi world, whereas the pro user will have to swallow surprisingly hard on this price. This is not the place to discuss where that difference might come from. I find the price to be highly reasonable for a loudspeaker that tells me the whole story without artificially „enhancing“ it.

Great work!